

HIGH PERFORMANCE CURRENT REGULATORS REVISITED

A Special Note: This test data is still very preliminary, and subject to changes. It is being shared for purposes of commentary and critique.

Several readers wrote in with comments and questions related to the use of the LM317 and MOSFET current sources within parts one and two of "Sources 101"^{1, 2}. These experiences (not all of which were good) led to the following discussion of two "all-weather" current sources/sinks. These current sources are suitable for virtually any type of audio application—that is, either power related or within the signal path, at currents from just a few to 100mA.

TWO "ALL-WEATHER" CURRENT SOURCES/SINKS USING MOSFET CASCODES

The key development that came about deals with the improved MOSFET cascode current sources of Fig. 1, both using the DN2540 depletion mode MOSFETs. There are really a couple of parts to this story-within-a-story. One is that it was in part stimulated by some e-mail exchanges, the first of which used a MOSFET current source in a power amp. More importantly however, some

later e-mail discussions revealed disappointing performance with the original Fig. 13C², when this circuit was used as an active load for a triode preamp stage. This was traced to an excessive white noise output, which in turn was due to the use of the LM317 within Fig. 13C. In this circuit the LM317 establishes the basic current operation of the circuit, insofar as noise properties.

Although my own original use of the Fig. 13C circuit was within a power supply regulator, I made a definite mistake in not establishing a caveat on noise vis-à-vis the LM317, if used within signal path circuits. Its noise level is such that while it might be OK for use as a push-pull power stage cathode bias (i.e., high level), it definitely isn't suited for lower level stages. In fact, the feedback I got was this: The Fig. 13C circuit was indeed OK in the high level tube applications, but not in preamps—due to a high residual hiss level. I apologize for not anticipating this type of use, and regret any inconvenience caused.

Fortunately, there is a simple and very attractive alternate solution—just use one of the two following advanced DN2540 cascode circuits. And, the second part of the story comes from the

stellar performance achieved with these cascodes. It took some special means to see just how good they really are!

The schematic of the new circuits is shown in Fig. 1, which consists of a conventional cascode (left), plus what I think is a very useful wrinkle, a bias-multiplying cascode (right). The left circuit isn't really new, because it is a relatively straightforward application of FET device cascoding, and this setup is similar to what my correspondents used. As discussed¹, it is usually desirable in this type of circuit to have the V_{gs} (off) of the upper device (M2) be specified as substantially higher than the lower part (M1). But, if two identical parts are used just as shown, the D-S voltage seen by M1 becomes the V_{gs} of M2—not always best for highest rejection. Nevertheless, with a simple circuit such as this, and no other high V_{gs} (off) family parts to use, you use what's available, the same part for M1 and M2. And, it still works, quite well, in fact.

The slightly more complex circuit to the right adds a second pair of resistors, which provide a DC gain for the gate bias of M2, as:

$$V_{DS}(M1) = V_{GS}(M2) * (1 + R3/R4)$$

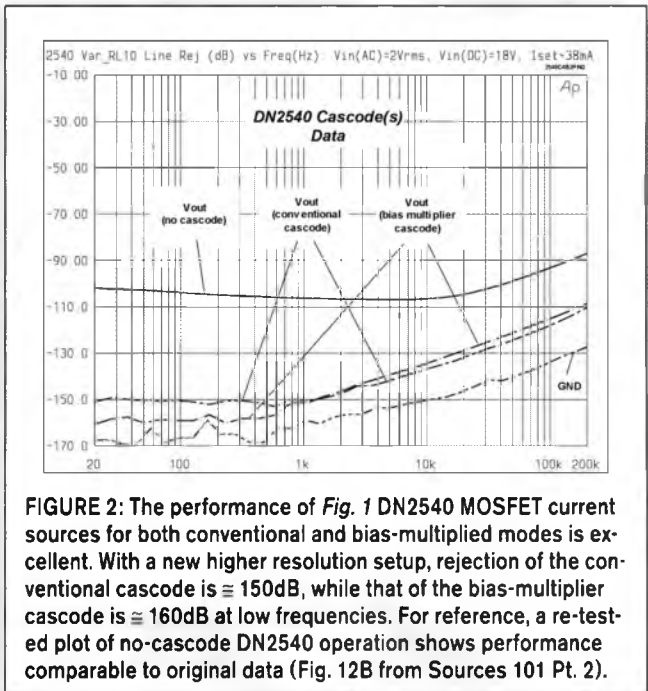
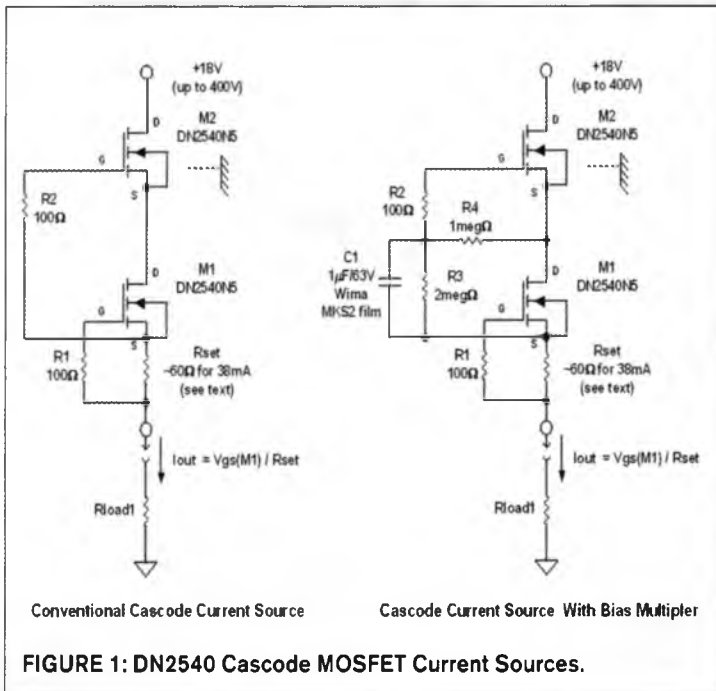

FIGURE 2: The performance of Fig. 1 DN2540 MOSFET current sources for both conventional and bias-multiplied modes is excellent. With a new higher resolution setup, rejection of the conventional cascode is ≈ 150 dB, while that of the bias-multiplier cascode is ≈ 160 dB at low frequencies. For reference, a re-tested plot of no-cascode DN2540 operation shows performance comparable to original data (Fig. 12B from Sources 101 Pt. 2).

So, if the DC bias of M2 is, for example, 2V, the resistor ratio shown increases it to 4× this, or 8V. This multiplied bias then becomes the V_{DS} of M1. This higher bias should enhance the M1 rejection characteristics for input changes, as it moves M1 V_{DS} further into its pentode region. The capacitor C1 bypasses R3, for lowest overall noise.

This approach allows noiseless biasing of this cascode, i.e., selective biasing without the use of V_s dividers, or batteries. When I first tested the bias-multiplying cascode, I couldn't see any improvement vis-à-vis the conventional type (left). Both circuit forms showed performance virtually indistinguishable from the setup noise floor.

But, I had also made some further setup improvements, which have a direct bearing on measurable results for these circuits. Here's what I did to change the test setup from that previously described¹.

1. Raised the test circuit drive to the DUT to $V_{in}(AC)$ 2V RMS, which adds 6dB of dynamic range vis-à-vis the original 1V RMS setup.
2. Changed test load resistor R_{load1} to 10Ω , a step which adds 20dB more sensitivity to the V_{out} error voltage. To be valid, this step assumes that all Z_s being measured are $\gg 10\Omega$, which they are in all cases thus far (in this DN2540 case, it turns out that the measured Z is on the order of $100M\Omega$ or more).
3. Created new Audio Precision software to do a rescaling of the output data files, so that all measured data points in a given sweep are reduced by 20dB (the ratio of the R_{load1} change, or 10:1). This effectively brings the setup calibration back to a 1Ω load reference. It also offsets the displayed dynamic range 20dB, downward. The total *display* dynamic range shown is still 160dB. It effectively adds 20dB more to the lower end of the measuring dynamic range, as the noise is effectively reduced relative to the V_{out} signal. In these plots, the 0dB reference trace isn't shown, but it is/was calibrated prior to a test run. The working test range was also calibration-checked at low levels, with a $10M\Omega$ resistor, resulting in a nice flat line at -139.9dB (just about as it should be,

with a measured -140dB being ideal).

The resulting test plots of Fig. 2 are for the Supertex DN2540N5 TO-220 part(s) operated at 38mA, a current level that corresponds roughly to similar data². It is easy to see the additional dynamic range here, which extends to -170dB. The plot which is repeated for the non-cascode 2540 operation is almost identical to the original 2540 plot at a 30mA level (Fig. 12B²).

A focus of this particular experiment was to discern whether the bias-multiplying cascode version (Fig. 1, right) really did make a difference in terms of rejection, vis-à-vis a more conventional version (Fig. 1, left), where the upper FET's gate is tied directly to the lower FET's source. Lo and behold from Fig. 2, yes, it does seem to make a difference! The rejection is better with the extra DC bias, just as theory says it should. The amount is about 10dB, not an overwhelming amount, but also clearly an improvement. This difference might change to even more between the two operative modes, were M1/M2 to see additional

drain voltage. Here each sees at the most about 9V, which isn't very high for a 400V part. Interestingly, I couldn't see this differentiation at all, with the older setup and $R_{load1} = 1\Omega$. With the load of 10Ω , it is easy to see.

SELF-GENERATED NOISE

All of the aforementioned tests are relevant to synchronous noise of a current source circuit, which is noise that is related to AC components of the unregulated power source. But, another important noise type is *self-generated noise*, which is the form generated by a device (or circuit) with a steady DC bias. It is this type of noise that led to the relatively poor performance of the LM317 cascode circuit in the preamp stage. Generally this type of noise—white noise—is relatively constant over a wide range of frequencies, and typically manifests itself (audibly) as hiss.

In a test series planned for a future *audioXpress* article, I tested several different current source circuits for self-generated noise, including the LM317 and DN2540, with a test DC operating

current of 10mA. I measured the noise components of the output current with a 100Ω resistor, an appropriate scaling amplifier, a 10kHz low-pass filter, and an RMS responding voltmeter.

To summarize in a few words, the DN2540 at 10mA came in more than 50 times lower in noise vis-à-vis the LM317, for similar conditions. Expressed in terms of noise density in pA/√Hz, the LM317 was over 1000 pA/√Hz, with the DN2540 less than 14pA/√Hz. Note: *These figures couldn't be called exact, in particular for the DN2540, where the noise is on a par with the input amplifier of the test setup. However, the main point here is simply that the DN2540 is many times lower in noise than the LM317.*

CONCLUSION

So, these two MOSFET cascodes can be termed "all-weather" current sources, because they can operate as either current sources or current sinks. They are also all-weather from the standpoint of a tremendous current range capability, from just a few mA up to 100mA or more. Plus, of course, there is the wide voltage range, up to 400V. Suitable for a wide range of solid-state or tube uses, in

power or signal circuits, the Fig. 1 configurations are the most versatile of any discussed. I recommend them without any major reservations. Although the TO-220 package of the DN2540N5 could be a downside for low power uses, there is a handy alternate, the TO-92 DN2540N3 (same internal chip).

ACKNOWLEDGMENTS

Henk Huitema, John Tracy and Ben Veltmaat provided useful feedback on their experiences using these current sources, within original correspondences taking place in Sept 2007. My thanks to all of them. In their final setup, they all reported successful use of the Fig. 1 (left) cascode. This cascode type has previously been discussed⁵.

REFERENCES

1. Walt Jung, "Sources 101: Audio Current Regulator Tests for High Performance, Part 1," *audioXpress*, April 2007, pp. 10-23.
2. Walt Jung, "Sources 101: Audio Current Regulator Tests for High Performance, Part 2," *audioXpress*, May 2007, pp. 8-17.
3. Walt Jung, Response to correspondence from Thomas Bohley, Chris Paul, and John Popelish, Xpress Mail *audioXpress*, September 2007, pp. 56-58.
4. Walt Jung, Response to correspondence from Marc Whitney, Xpress Mail *audioXpress*, September 2007, pp. 58-60.
5. Ixys IXCP10M45s forum thread at: www.diyaudio.com/forums/showthread.php?s=9c690653b3b7ba542b30545a1556ab9c&threadid=102335&perpage=25&highlight=&pagenumber=4.

The following correction note was sent to AudioXpress March 14, 2009 regarding the publication of the letter above.

In AudioXpress April 2009 pp. 40-42, my letter looks OK in many regards, but does have some errors needing correction.

1) The redundant "Special Note:" disclaimer in bold should have been deleted.

2) No author is mentioned; it should have been signed as this letter.

3) On P41 top, 1st column, the first sentence should read as: "So, if the DC bias of M2 is for example 2V, the resistor ratio shown increases it to 3x this, or 6V." The general expression for multiplied bias voltage in the previous paragraph portion ending on p 40 is OK.

Walt Jung

<waltjung@waltjung.org>